

Aufbau

| | |
|------------------|---------------------------------------|
| Hutmutter | Messing CuZn39Pb3, galv. vernickelt |
| Lamelleneinsatz | Polyamid PA6 V-2 |
| Dichtring | Polychloropren-Nitrilkautschuk CR/NBR |
| Zwischenstützen | Messing CuZn39Pb3, galv. vernickelt |
| O-Ring | Nitrilkautschuk NBR |
| Anschlussgewinde | Pg, nach DIN 40430 |

Eigenschaften

| | |
|-------------------|---|
| | <ul style="list-style-type: none"> • für Kabel und Leitungen mit Schirmung • integrierte Zugentlastung • Verdrehenschutz • großer Dicht- und Klemmbereich |
| Temperaturbereich | -20°C +100°C |
| Schutzart | IP68 5bar |

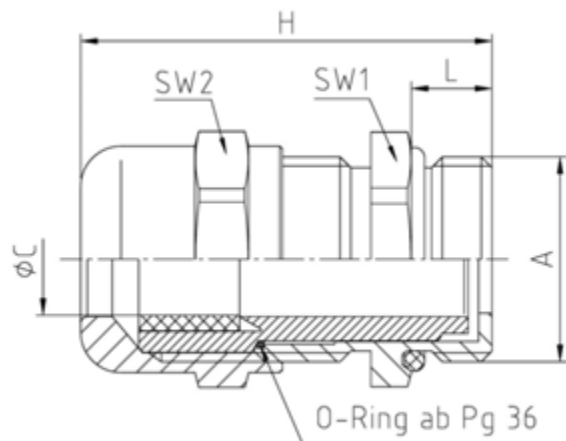

Merkmale

Anschlussgewinde Standardlänge

| A | ØC | L | SW1 | SW2 | H |  | Art.-Nr. |
|---------|---------|-----|-----|-----|-------------------|--|------------|
| | mm | mm | mm | mm | mm | Stück | |
| Pg 7 | 3 - 6,5 | 5 | 14 | 14 | 24 | 100 | 50.007/EMV |
| Pg 9 | 4 - 8 | 6 | 17 | 17 | 29 | 100 | 50.009/EMV |
| Pg 11 | 5 - 10 | 6 | 20 | 20 | 29,5 | 100 | 50.011/EMV |
| Pg 13,5 | 6 - 12 | 6,5 | 22 | 22 | 31,5 | 50 | 50.013/EMV |
| Pg 16 | 10 - 14 | 6,5 | 24 | 24 | 31,5 ¹ | 50 | 50.016/EMV |
| Pg 21 | 13 - 18 | 7 | 30 | 30 | 34 | 25 | 50.021/EMV |
| Pg 29 | 18 - 25 | 8 | 40 | 40 | 39 | 25 | 50.029/EMV |

| A | ØC | L | SW1 | SW2 | H |  | Art.-Nr. |
|-------|---------|----|-----|-----|----|--|------------|
| | mm | mm | mm | mm | mm | Stück | |
| Pg 36 | 24 - 32 | 9 | 50 | 50 | 45 | 10 | 50.036/EMV |
| Pg 42 | 30 - 38 | 10 | 57 | 57 | 49 | 5 | 50.042/EMV |
| Pg 48 | 34 - 44 | 10 | 64 | 64 | 52 | 5 | 50.048/EMV |